



## *Moulded Pattress Boxes*



In creating the modern, aesthetically pleasing and ergonomic design of the CURVA range we did not lose sight of the need to produce a true value for money product offering the upmost appeal to installers and end users alike.

Only the best quality raw materials were used in producing this durable, attractive and modern range of accessories which will adorn the walls of all manner of buildings for years to come.

## Moulded Pattress Boxes

### Product Range

#### Moulded Pattress Boxes

<b>CCA080</b>	1 Gang 16mm Deep Pattress Box With Earth Terminal
<b>CCA081</b>	1 Gang 25mm Deep Pattress Box
<b>CCA082</b>	2 Gang 25mm Deep Pattress Box
<b>CCA083</b>	1 Gang 35mm Deep Pattress Box
<b>CCA084</b>	2 Gang 35mm Deep Pattress Box
<b>CCA085</b>	1 Gang 47mm Deep Pattress Box With Earth Terminal
<b>CCA086</b>	2 Gang 47mm Deep Pattress Box With Cable Restraint & Earth Terminal



CCA080



CCA081



CCA083



CCA085

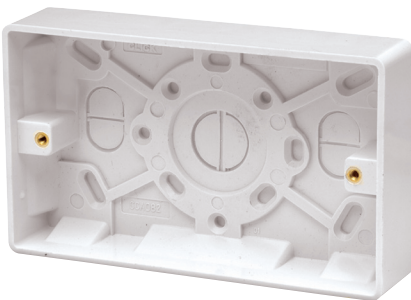

CCA082

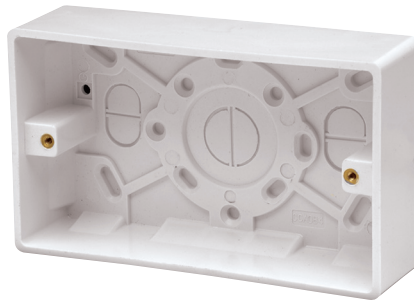

CCA084



CCA086

**Moulded Pattress Boxes**

**Product Dimensional Drawings (mm)**

CCA080, 081, 083, 085

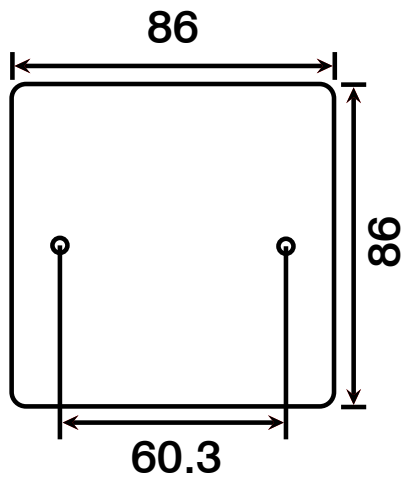

CCA082, 084, 086

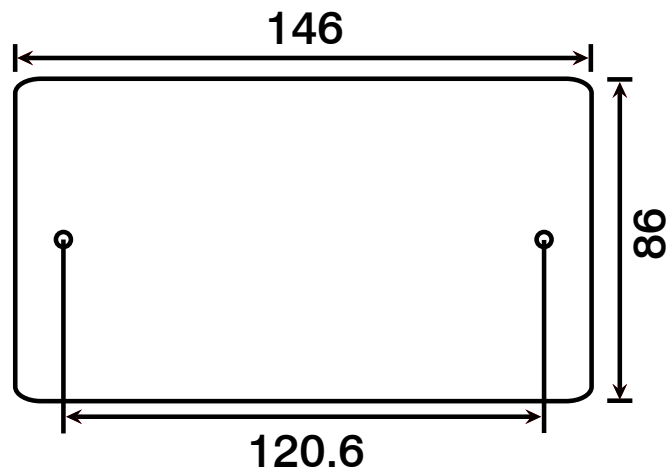

## Moulded Pattress Boxes

### Technical Specification

#### Moulded Pattress Boxes

<b>Material Composition</b>	Pattress Box: Urea
<b>Back Box Depths</b>	16mm - 47mm
<b>Earth Terminal</b>	(CCA080, CCA085 & CCA086)
<b>Cable Restraint</b>	(CCA086)
<b>Warranty</b>	10 Years
<b>Anti Microbial Certified</b>	Yes
<b>IP Rating</b>	IP20
<b>Operational Temperature</b>	-5° to +40°C
<b>Standards</b>	BS 5733 : 2010 + A1 : 2014 Modified ISO 22196

#### Additional Information

Ensure that the mains supply is isolated before commencing installation and refer to the circuit diagram with the relevant product.

Bare earth cables must always be covered with appropriate sleeving and wired to the earth terminal.

All white moulded accessories are manufactured using Urea Formaldehyde, which has similar inherent properties to antimicrobial additives that inhibit the growth of infectious diseases. All products were independently tested and achieved a 99.9% kill rate across all four types of the strains of bacteria - MRSA, E-Coli, Salmonella, and Klebsiella Pneumoniae.



DECLARATION OF CONFORMITY

1. *Issuer Name* Scolmore International Limited
2. *Issuer Address* 1 Scolmore Park, Landsberg,  
Lichfield Road Industrial Estate,  
Tamworth, Staffordshire, B79 7XB
3. *Object(s) of Declaration* Curva Range
  - a. *Group* Pattress Boxes
  - b. *Model No.* CCA080, CCA081, CCA082, CCA083, CCA084, CCA085, CCA086
4. *The object of the declaration described above is in conformity with the requirements of the following Legislations:*
5. *All products contained within the aforementioned comply with the relevant standards and requirements listed below.*

BS 5733 : 2010 + A1 : 2014

6. *I hereby declare that the equipment named above has been designed to comply with the relevant sections of the above referenced specifications. The unit complies with all applicable Essential Requirements of the Directives.*

*In conjunction with the above all manufacture and process controls are in accordance with ISO 9001:2008*

Signed, for and on behalf of: Scolmore International Limited

Steven Bettson BSc - Senior Technical Support Engineer

**CE 15**